

# Fuji USER MANUAL

## STRAIGHT GRINDERS

MODEL : FG-3H-7



FG-3H-7

### SPECIFICATIONS

Model	Max.Dia (Grinding Wheel)	Rotational Frequency	Spindle Thread Size	Overall Length	Mass	Max. Air Consumption	Air Inlet Thread Size	Air Hose Size
	mm	min <sup>-1</sup>		mm	kg	m <sup>3</sup> /min		mm
FG-3H-7	100 × 6 × 9.53	12,000	W3/8-16	317	1.4	0.55	Rc 3/8	9.5

The performance figures are at 0.63 MPa(6.3bar).



Refer to "The Instructions and Warning for Safety Use" enclosed in each tool box.

Fuji Industrial Technique Co.,Ltd.

2-1-14, Kamiji, Higashinari-ku, Osaka, 537-0003 Japan

Tel : 81-6-6972-2335

Fax : 81-6-6972-2380

ASSEMBLY TOOLS

ABRASIVE TOOLS

DRILLS / TAPPERS

PERCUSSIVE TOOLS

AIR MOTORS

OTHER PRODUCTS

# MODEL : FG-3H-7

## EXPLODED VIEW

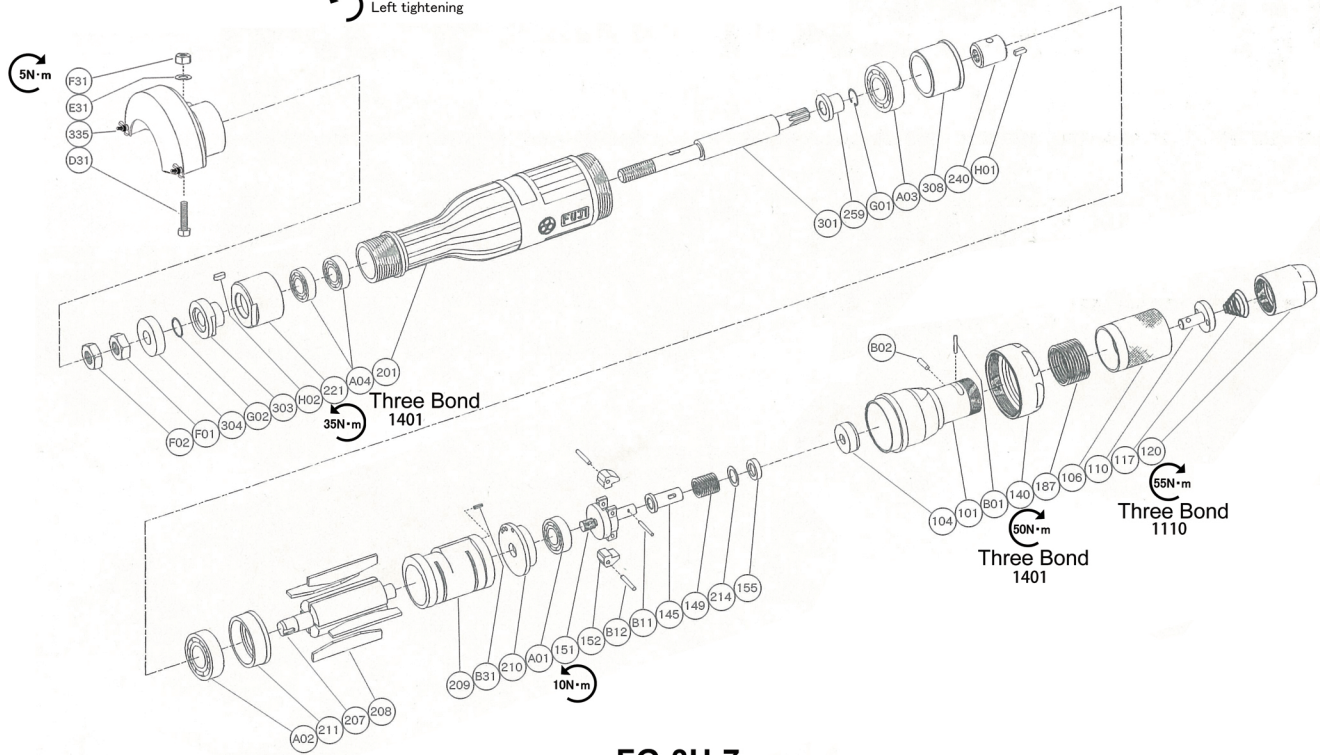
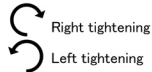

FG-3H-7

## PARTS LIST

Index No.	Parts No.	Parts Name	Qty
FG-3H-7			
—	G-101001-00	Housing Cover Ass'y (Rc)	
101	G-101001-50	Housing Cover	1
(104)	G-101104-00	Bushing	1
106	G-042106-04	Throttle Valve Handle	1
110	G-042110-00	Throttle Valve	1
117	G-042117-00	Throttle Valve Spring	1
120	G-042120-00	Throttle Valve Cover (Rc)	1
187	G-042187-00	Throttle Valve Handle Spring	1
B01	NR-316.8	Needle Roller	1
B02	NR-39.8	Needle Roller	1
—	A-107010-00	Governor Weight Ass'y	
151	A-107151-01	Governor Cage	1
152	A-010152-00	Governor Weight	2
B12	GP-2.516GCH	Grooved Pin	2
140	G-101140-00	Cup Nut	1
145	A-065145-00	Governor Valve	1
149	G-063149-01	Governor Valve Spring	1
155	A-065155-00	Governor Valve Spring Holder	1
201	G-161201-00	Housing	1
207	A-107207-00	Rotor	1
208	G-103208-00	Rotor Blade	4
209	G-161209-00	Cylinder	1
(B31)	SP-26	Spring Pin	1
210	A-107210-00	Cylinder Upper Plate	1
211	A-107211-00	Cylinder Lower Plate	1
214	A-065214-00	Adjusting Washer (T=0.2)	1
221	G-161221-00	Spindle Bearing Cover	1
240	G-161240-00	Coupling	1
259	G-161259-00	Inner Race	1
301	G-161301-00	Wheel Spindle	1
303	G-161303-04	Wheel Flange (A)	1

Index No.	Parts No.	Parts Name	Qty
304	G-170304-04	Wheel Flange (B)	1
308	G-161308-00	Spacer	1
335	G-161335-03	Wheel Guard	1
(D31)	HS-625	Hexagon Bolt	1
(E31)	SW-6	Spring Washer	1
(F31)	N-6	Nut	1
A01	BB-609MN	Ball Bearing	1
A02	BB-6200	Ball Bearing	1
A03	BB-6201	Ball Bearing	1
A04	BB-EE3	Ball Bearing	2
B11	NR-211.8	Needle Roller	1
F01	N-W3/8	Nut	1
F02	N-W3/8(3)	Nut	1
G01	SR-S9	Snap Ring	1
G02	SR-SA10	Snap Ring	1
H01	K-338F	Key	1
H02	K-338	Key	1

- The related parts are shown in a thick frame.
- #101, 209 and #335 are supplied together with parts shown in ( ).
- Specify parts number and quantity when ordering.

■ Standard Accessory

AC No.	Description	Qty
F-112	32mm Open-End Wrench	1