

Fuji USER MANUAL

—IMPACT WRENCHES & DRIVER— (Oil Bath Type) MODELS : FW-66SA-1 & FW-66SAD-1,-10



FW-66SA-1



FW-66SAD-1, -10

SPECIFICATIONS

Model	Capacity (Guidance)		Free Speed	Side to Center		Square Drive Size		Bit Shank Size		Overall Length		Mass		Air Consumption (Under Load)		Air Inlet Thread Size		Air Hose Size	
	mm	in		mm	in	mm	in	mm	in	mm	in	kg	lb	Nm ³ /min	Nft ³ /min	in	mm	in	
FW-66SA-1	5	1/4	5,000	22.5	57/64	9.5	3/8	—	—	212	8 11/32	0.78	1.7	0.40	14.1	PT or NPT 1/4	6.3	1/4	
FW-66SAD-1	5	1/4	5,000	22.5	57/64	—	—	6.35	1/4	218	8 19/32	0.78	1.7	0.40	14.1	PT or NPT 1/4	6.3	1/4	
FW-66SAD-10	5	1/4	5,000	22.5	57/64	—	—	6.35	1/4	218	8 19/32	0.78	1.7	0.40	14.1	PT or NPT 1/4	6.3	1/4	

The performance figures are at 0.63MPa (6.3bar).

 Refer to "The Instructions and Warning for Safety Use" enclosed in each tool box.

Fuji Industrial Technique Co.,Ltd.

2-1-14, Kamiji, Higashinari-ku, Osaka, 537-0003 Japan

Tel : 81-6-6972-2335

Fax : 81-6-6972-2380

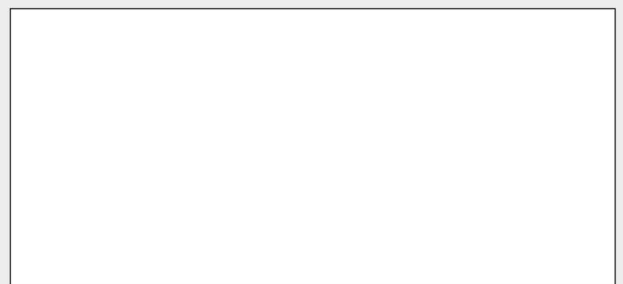

MODELS : FW-66SA-1 & FW-66SAD-1, -10

EXPLODED VIEW

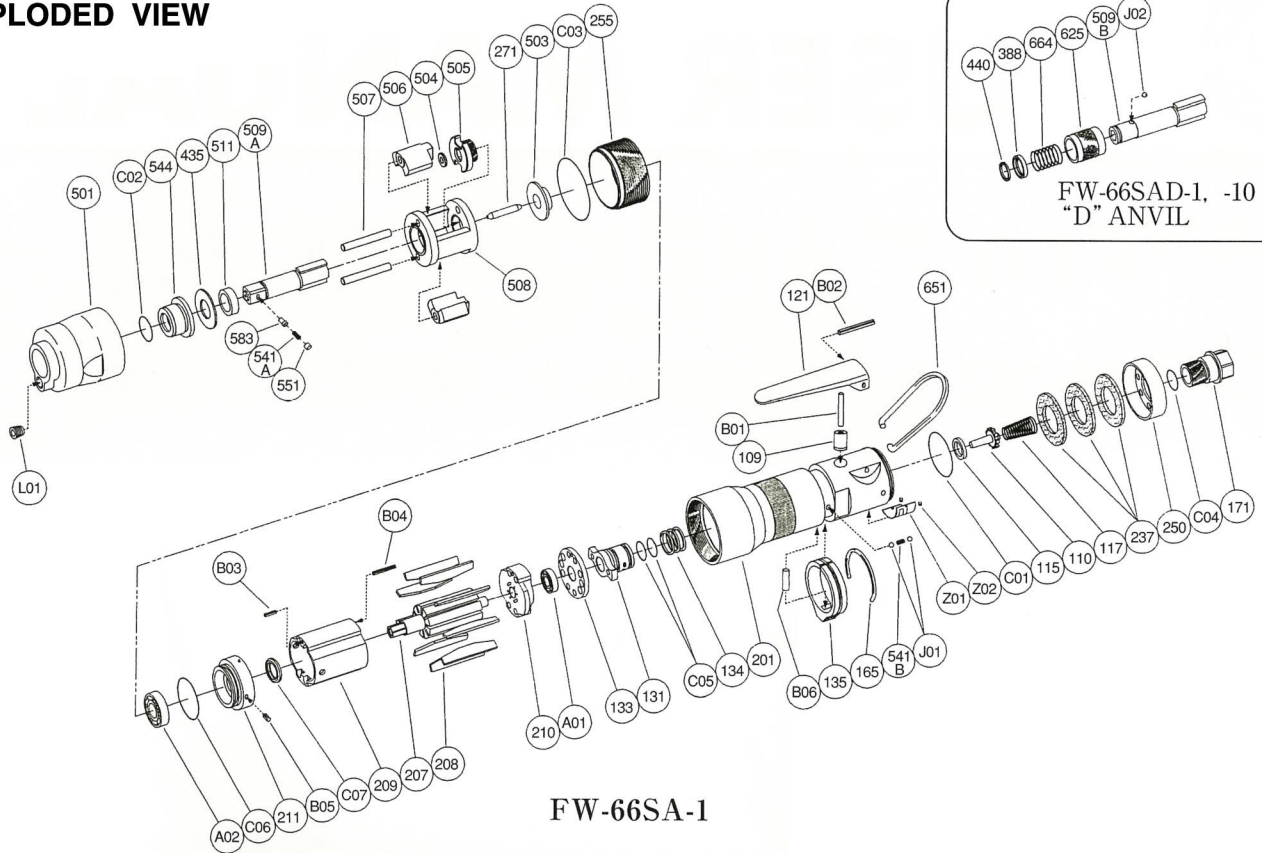

PARTS LIST

Index No.	Parts No.	Parts Name	Qt.
FW-66SA-1			
FW-66SAD-1, -10			
CP No.	W-308006-00	Housing C.P	
109	W-299109-00	Throttle Valve Bushing	1
110	W-299110-00	Throttle Valve	1
115	W-299115-00	Throttle Valve Sheet	1
117	D-001117-00	Throttle Valve Spring	1
121	M-073121-00	Throttle Valve Lever	1
171	W-299171-00	Inlet Bushing (PT)	1
171	W-299171-01	Inlet Bushing (NPT)	1
201	W-308201-00	Housing	1
237	W-299237-00	Muffler Pad	3
250	W-299250-00	Exhaust Cover	1
B01	NR-321FR	Needle Roller	1
B02	SP-325	Spring Pin	1
C01	O-S28F	" O " Ring	1
CP No.	W-314013-00	Clutch Housing C.P	
C02	O-P12F	" O " Ring	1
C03	O-S39	" O " Ring	1
L01	PL-1/16	Plug	1
CP No.	W-314013-50	Clutch Housing Semi C.P	
501	W-314501-00	Clutch Housing	1
544	W-242544-00	Clutch Housing Bushing	1
FW-66SA-1			
131	W-299131-00	Reverse Valve	1
133	W-299133-00	Reverse Valve Sheet	1
134	W-299134-00	Reverse Valve Spring	1
135	W-216135-00	Reverse Valve Lever	1
165	W-216165-00	Stop Ring	1
207	W-314207-00	Rotor	1
208	W-285208-00	Rotor Blade	9
209	W-298209-00	Cylinder	1
(B03)	SP-28	Spring Pin	1
(B04)	SP-216	Spring Pin	1
210	W-299210-00	Cylinder Upper Plate	1

□ CP No. denotes the assembled parts comprising of more than 1 pc. of parts. The related parts are shown in the thick frame.

□ #209, 211 and 509A are supplied together with parts shown in ().

Index No.	Parts No.	Parts Name	Qt.
211	W-327211-00	Cylinder Lower Plate	1
(B05)	SP-2.55	Spring Pin	1
255	W-314255-00	Motor Fastening Nut	1
271	W-191271-00	Rotor Pin	1
435	W-242435-00	Thrust Washer	1
503	W-314503-00	Spacer (B)	1
504	W-305504-00	Spacer (C)	1
505	W-305505-00	Cam	1
506	W-305506-00	Hammer Clutch	2
507	W-242507-00	Clutch Pin	2
508	W-242508-00	Clutch Frame	1
509A	W-305509-03	Anvil (B)	1
(541A)	W-252541-00	Button Retainer Spring (F)	1
(551)	W-252551-00	Plug	1
(583)	W-252583-00	Retainer Button (F)	1
511	W-242511-00	Clutch Frame Bushing	1
541B	W-252541-00	Button Retainer Spring (F)	1
651	W-100651-00	Hanger	1
A01	BB-EE2	Ball Bearing	1
A02	BB-6900	Ball Bearing	1
B06	NR-413.5	Needle Roller	1
C04	O-S12.5	" O " Ring	1
C05	O-S12.5	" O " Ring	2
C06	O-S24	" O " Ring	1
C07	O-4111	Quad Ring	1
J01	B-3	Ball	2
Z01	NP-1135	Name Plate	1
Z02	NPN-0×3.2	Screw Rivet	2
FW-66SAD-1, -10			
388	W-305388-00	Spring Holder	1
440	W-305440-00	Ring	1
509B	W-305509-01	Anvil (D) (For FW-66SAD-1)	1
509B	W-305509-00	Anvil (D) (For FW-66SAD-10)	1
625	W-305625-00	Bit Cover	1
664	W-305664-00	Finder Spring	1
J02	B-3	Ball	1

□ Specify parts number and quantity in ordering.