

Fuji USER MANUAL

STRAIGHT GRINDERS

MODELS : FG-3H-2,-2F

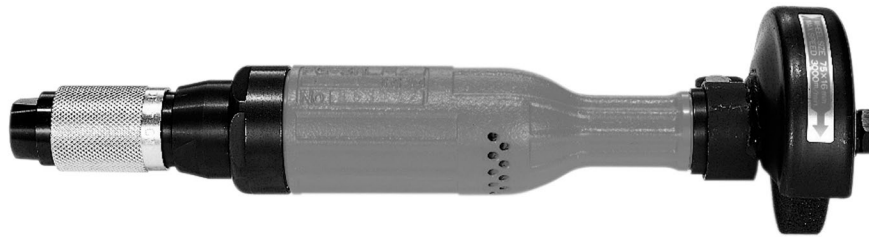

FG-3H-2



FG-3H-2F

SPECIFICATIONS

Model	Max. Dia. (Grinding Wheel)		Rotational Frequency	Spindle Thread Size	Overall Length		Mass		Max. Air Consumption		Air Inlet Thread Size	Air Hose Size	
	mm	in			mm	in	kg	lb	m ³ /min	ft ³ /min		mm	in
FG-3H-2	75×13×9.53	3×1/2×3/8	12700	3/8-16	317	12 31/64	1.5	3.3	0.55	19.4	Rc 3/8	9.5	3/8
FG-3H-2F	75×13×9.53	3×1/2×3/8	12700	3/8-16	342	13 15/32	1.7	3.7	0.55	19.4	Rc or NPT 3/8	9.5	3/8

The performance figures are at 0.63 MPa(6.3bar).



Refer to "The Instructions and Warning for Safety Use" enclosed in each tool box.

Fuji Industrial Technique Co.,Ltd.

2-1-14, Kamiji, Higashinari-ku, Osaka, 537-0003 Japan

Tel : 81-6-6972-2335

Fax : 81-6-6972-2380

ASSEMBLY TOOLS

ABRASIVE TOOLS

DRILLS / TAPPERS

PERCUSSIVE TOOLS

AIR MOTORS

OTHER PRODUCTS

MODELS : FG-3H-2, -2F

EXPLODED VIEW

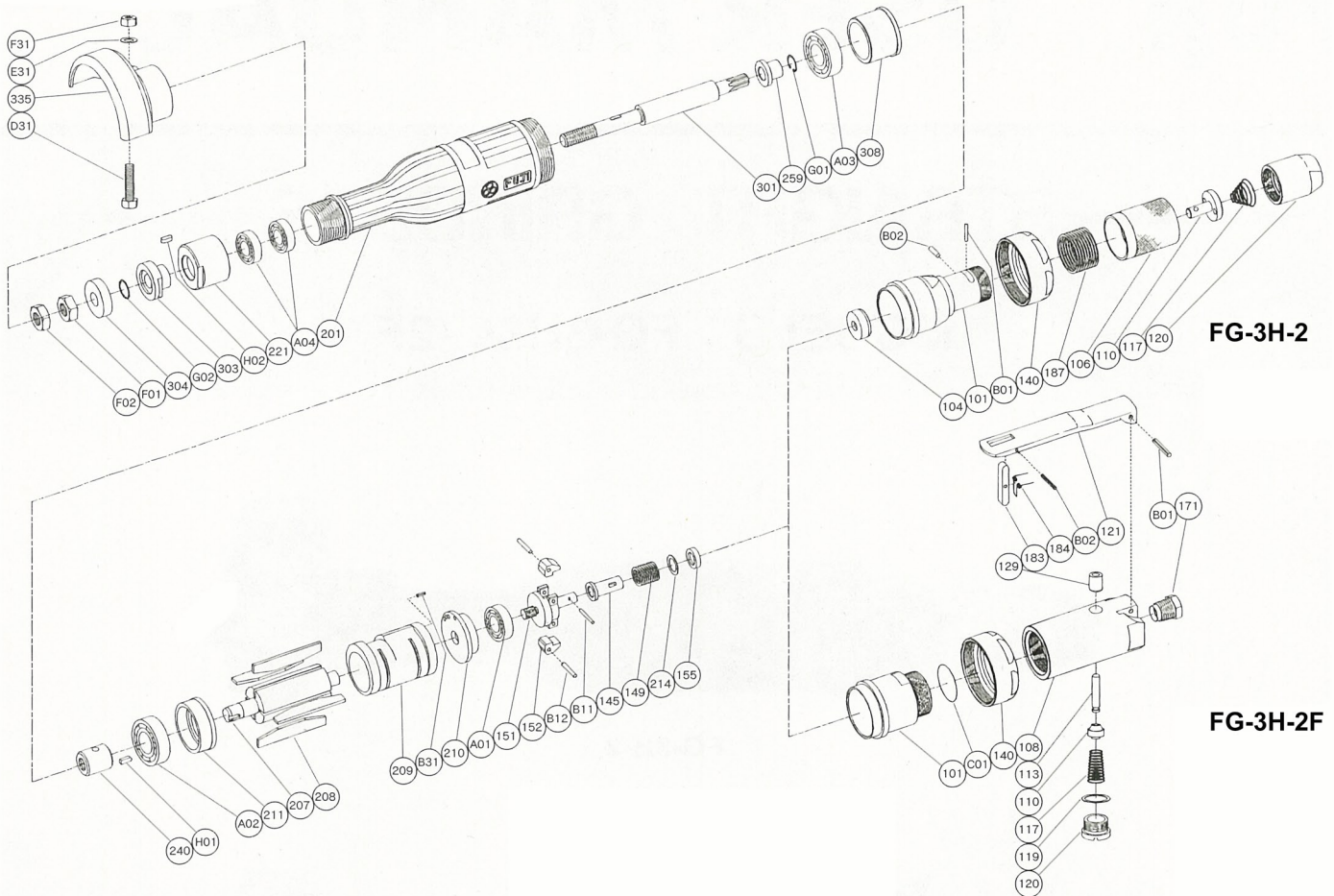

PARTS LIST

Index No.	Parts No.	Parts Name	Qty
FG-3H-2			
—	G-101001-00	Housing Cover Ass'y<Rc>	
101	G-101001-50	Housing Cover	1
(104)	G-101104-00	Bushing	1
106	G-042106-04	Throttle Valve Handle	1
110	G-042110-00	Throttle Valve	1
117	G-042117-00	Throttle Valve Spring	1
120	G-042120-00	Throttle Valve Cover<Rc>	1
187	G-042187-00	Throttle Valve Handle Spring	1
B01	NR-316.8	Needle Roller	1
B02	NR-39.8	Needle Roller	1
FG-3H-2F			
—	A-107001-02	Housing Cover Ass'y	
101	G-161101-00	Housing Cover	1
140	G-101140-00	Cup Nut	1
C01	O-S26	"O" Ring	1
—	A-107003-02	Throttle Valve Body Ass'y<Rc>	
—	A-107003-03	Throttle Valve Body Ass'y<NPT>	
108	A-107003-50	Throttle Valve Body	1
(129)	H-014129-00	Throttle Valve Rod Bushing	1
110	H-001110-02	Throttle Valve	1
113	G-028113-00	Throttle Valve Rod	1
117	D-001117-00	Throttle Valve Spring	1
119	G-028119-00	T.V. Cover Packing	1

Index No.	Parts No.	Parts Name	Qty
120	G-028120-00	Throttle Valve Cover	1
171	IB-4030S0	Inlet Bushing<Rc>	1
	IB-403NS0	Inlet Bushing<NPT>	1
B01	SP-320	Spring Pin	1
—	G-144019-01	Lock Lever Ass'y	
121	G-144121-02	Throttle Valve Lever	1
183	G-144183-02	Lock Key	1
184	G-144184-00	Lock Spring	1
B02	SP-218	Spring Pin	1
FG-3H-2, -2F			
—	A-107010-00	Governor Weight Ass'y	
151	A-107151-01	Governor Cage	1
152	A-010152-00	Governor Weight	2
B12	GP-2.516GCH	Grooved Pin	2
140	G-101140-00	Cup Nut<for FG-3H-2>	1
145	A-065145-00	Governor Valve	1
149	G-171149-00	Governor Valve Spring	1
155	A-065155-00	Governor Valve Spring Holder	1
201	G-161201-00	Housing	1
207	A-107207-00	Rotor	1
208	G-103208-00	Rotor Blade	4
209	G-161209-00	Cylinder	1
(B31)	SP-26	Spring Pin	1
210	A-107210-00	Cylinder Upper Plate	1
211	A-107211-00	Cylinder Lower Plate	1
214	A-065214-00	Adjusting Washer<T=0.2>	1

Index No.	Parts No.	Parts Name	Qty
	A-065214-01	Adjusting Washer<T=0.3>	1
	A-065214-02	Adjusting Washer<T=0.5>	1
221	G-161221-00	Spindle Bearing Cover	1
240	G-161240-00	Coupling	1
259	G-161259-00	Inner Race	1
301	G-161301-00	Wheel Spindle	1
303	G-161303-03	Wheel Flange<A>	1
304	G-161304-05	Wheel Flange	1
308	G-161308-00	Spacer	1
335	G-161335-01	Wheel Guard	1
(D31)	HS-625	Hexagon Bolt	1
(E31)	SW-6	Spring Washer	1
F31	N-6	Nut	1
A01	BB-609MN	Ball Bearing	1
A02	BB-6200	Ball Bearing	1
A03	BB-6201	Ball Bearing	1
A04	BB-EE3	Ball Bearing	2
B11	NR-211.8	Needle Roller	1
F01	N-W3/8	Nut	1
F02	N-W3/8(3)	Nut	1
G01	SR-S9	Snap Ring	1
G02	SR-SA10	Snap Ring	1
H01	K-338F	Key	1
H02	K-338	Key	1

- The related parts are shown in a thick frame.
- #101,108,209 and 335 are supplied together with parts shown in ().
- Specify parts number and quantity when ordering.

Standard Accessory

AC No.	Description	Qty
F-117	21mm Open-End Wrench	1

Optional Accessory

AC No.	Description	Qty
HN-303000	Hose Nipple	1